



LANDMARK
ELEVATOR

LANDMARK
ELEVATOR

Company: Suzhou Landmark Elevator Co Ltd

Add: No 388,Hi-Tech Economic Park, Suzhou City, Jiangsu, China.

Email: info@lmkelevator.com

Tel/Fax: +86-18068050532

[Http://www.lmkelevator.com](http://www.lmkelevator.com)

Suzhou Landmark Elevator Co., Ltd.
Elevator & Escalator



COMPANY PROFILE

Landmark Elevator, as a professional elevator and escalator manufacturer over years, sells to many countries and wins recognition of foreign clients. Landmark and has complied with all the national elevator and escalator with ISO quality certification. Landmark has technical experts with great experience to provide outstanding before-sales and after-sales service.

Landmark specializes in the supply of elevator package parts solution for new elevator, including machine, controller, door, safety parts and some mechanical items. Landmark also provides the regularly replaced parts for elevator maintenance and repair work, including door sensor, limit switch, photoelectric switch, door inverter, door motor, electrical inverter, main board etc. All these parts can be used for all brands of elevators including the brand elevator and escalator parts, like OTIS, SIGMA LG, Hyundai, KONE, Mitsubishi, etc.

Landmark focuses on the old elevator and escalator modernization job, in Otis, Mitsubishi, Thyssen etc all brands. It is a good economic option to modernize the old to make the passenger and the Owners happy with the elevator service. Landmark's professional technical teams follow up all the technical details, especially the before and after-sales technical evaluation to ensure the quality of parts and success of elevator modernization.

Landmark principle is "Customer-Oriented" & "Market-Oriented". We care about your interest and shall take full responsibility for all the works we do for our clients. Our goal to serve the clients in a better way is always fulfilled by all our staff. Landmark makes contributions in elevator service field for our clients and makes a fine cooperation with clients from all over the world.

Suzhou Landmark Elevator Co., Ltd.

- Vision: Leading Vertical Transport Solution Supplier.
- Mission: Building a Safe & Smart World.
- Core Values: "Three-Goods for Clients".
- Speak Good Words for Clients; Do Good Deeds for Clients; Keep Kind Hearts for Clients.

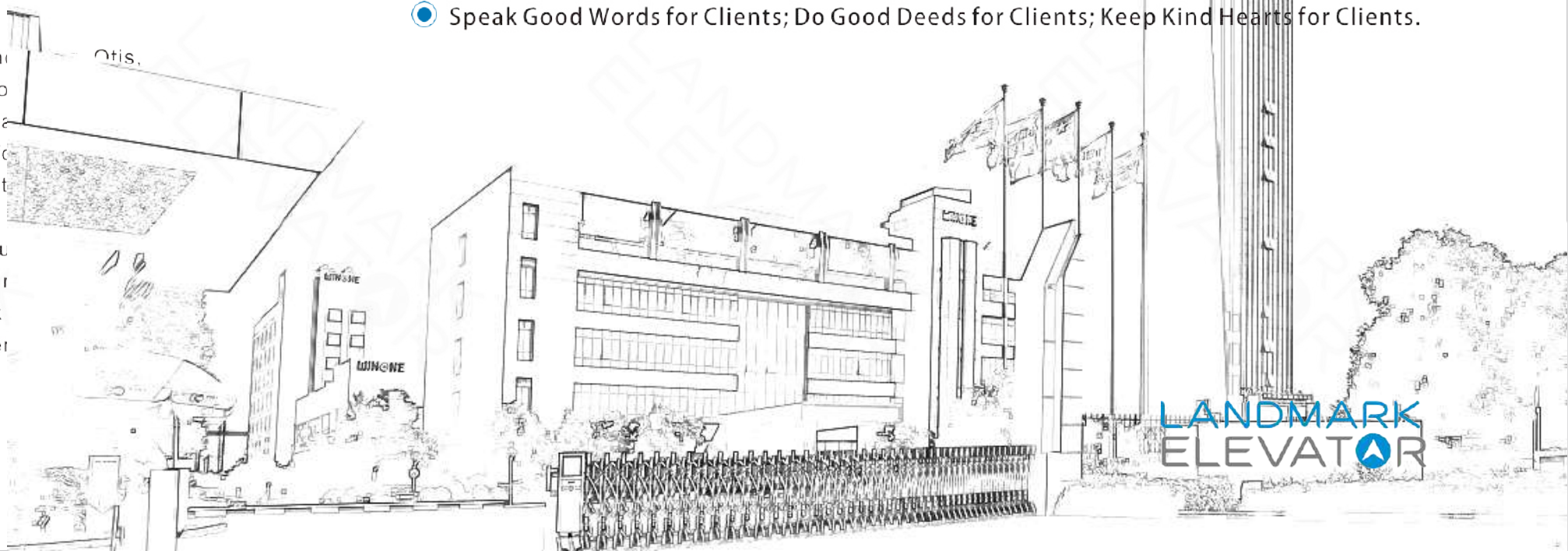

PRODUCT INTRODUCTION



Passenger Elevator

Our passenger elevators help people reach the floors quickly, comfortably, safely, and run quietly which is especially important at night. We make elevators be integrated into the buildings, and try to help building owners to reduce cost for total elevator lifetime with excellent solutions.



Hospital Bed Elevator

Our hospital bed elevators have large capacity and wide opening doors to accommodate stretchers, beds and other medical equipment, precise levelling to allow easy access for wheelchairs.



Freight Elevator

Our freight elevators are specially designed for the transportation of cargoes, big door opening, spacious cabin, strong structure, to ensure safe and steady running when loading large cargoes and people. They are the best transportation machines for factories, warehouses, and malls etc.



Panoramic Elevator

Our panoramic elevators are generally running in open environments like shopping malls, hotels, office buildings etc. We have various of designs for cabins which are elegant and beautiful, attract people's attention greatly. Your buildings must reach a higher level with our panoramic elevators.



Home Elevator

With our home elevator solutions, you can bring your ideal vision to life. We have a variety of cabin designs, there is always one for you. Even no pit, or the space limited, we can design a matched home elevator for you.



Escalator

Our serial escalators use reliable materials and branded parts, with strong structure, to keep escalators smooth running for long time with lower noise and low-cost maintenance. They become indispensable part of shopping malls, multiplex cinema, museums, train and metro stations, airports etc.

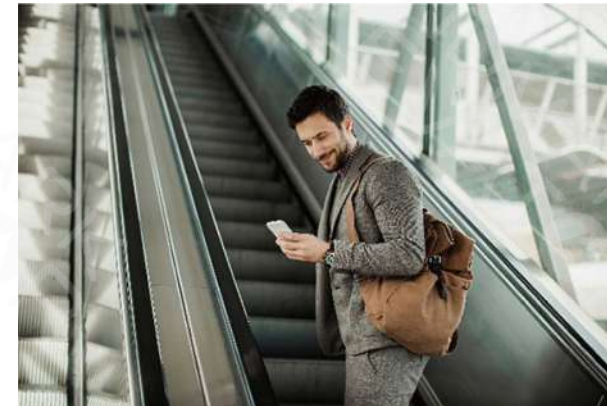

Moving Sidewalk

Our moving sidewalks have strong structure and high performance as our escalators. When your site has small angle but long span, you can choose moving sidewalks. They are popular using in high-grade shopping center, airport, big indoor place etc.



PASSENGER ELEVATOR



Small Machine Room Passenger Elevator

255mm

Reduce the height of the machine room 255mm

40%

Small machine room elevator, save machine-room area



Machine Roomless Passenger Elevator

100%

Machine roomless elevator, pure utility of construction area

25%

It saves 25% of electric energy

Normal Configuration



PO1A
(Standard)

Ceiling: Hairline stainless steel+LED lights

C.O.P: CZ001 (standard)

Car walls: Hairline stainless steel plate

Car door: T01

Floor: PVC/Marble



D02



F01



CZ001

WH002



T01

Hairline Stainless Steel

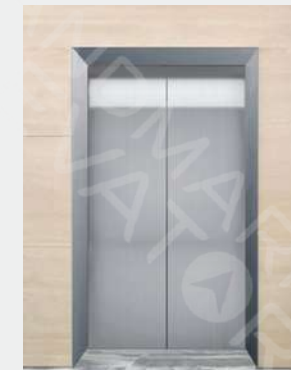

T02

Mirror Stainless Steel



T03

Painted Steel



T04

Safety Glass

PASSENGER ELEVATOR



MODERN & CONCISE STYLE



F01



F02



F03



F04



F05



F06



F07



F08



F09

PASSENGER ELEVATOR

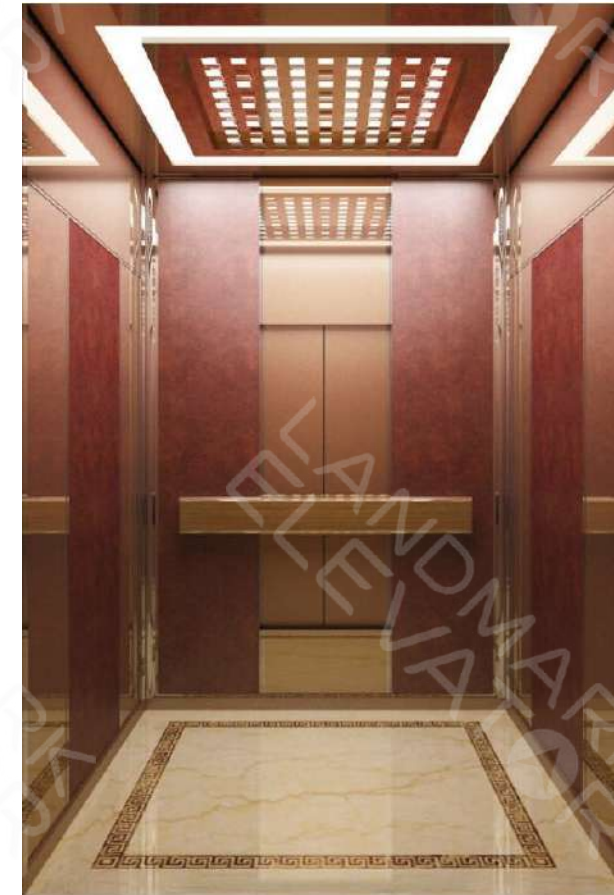

CBN-1315

Ceiling: Mirror ST.ST.Frame + Blasted ST.ST.+Acrylic + LED Spotlight
 Rear Wall:Black Blasted ST.ST.+ Fireproof Lamination + Mirror ST.ST.Trim
 Side Wall:Black Blasted ST.ST.+ Decorative Film +Mirror ST.ST.Trim
 Skirting: Black Blasted ST.ST.
 Flooring: Marble
 Front Wall:Black Mirror ST.ST.

CBN-1316

Ceiling: Mirror ST.ST.+LED Spotlight
 Rear Wall:Brushed ST.ST.+ Back-painted Glass
 Side Wall:Laminated Steel + Brushed ST.ST.
 Skirting:Mirror ST.ST.
 Flooring:Marble
 Front Wall: Mirror ST. ST.

CBN-1317

Ceiling: Rose-gold Mirror ST.ST.Frame + Acrylic + LED Strip Lighting
 Rear Wall:Simulated Leather Veneer + Rose-gold Mirror ST.ST.+ Mirror ST.ST.
 Side Wall:Simulated Leather Veneer + Rose-gold Mirror ST.ST.+ Mirror ST.ST.
 +Beveled Brown GlassMirror
 Handrail:Mirror ST.ST+ Wood Veneer
 Skirting: Rose-gold Brushed ST.ST.
 Flooring:Marble
 Front Wall:Rose-gold Brushed ST.ST.

CBN-1318

Ceiling: Rose-gold Mirror ST.ST.+ Acrylic
 Rear Wall: Rose-gold Brushed ST.ST.Etching+Rose Gold Mirror ST.ST.
 Side Wall: Rose Gold Brushed ST.ST.Etching+Rose Gold Mirror ST.ST.
 Handrail: Rose Gold Round ST.ST.Tube
 Skirting: Brushed ST.ST.
 Flooring: Marble
 Front Wall:Rose-gold Brushed ST.ST.

PASSENGER ELEVATOR

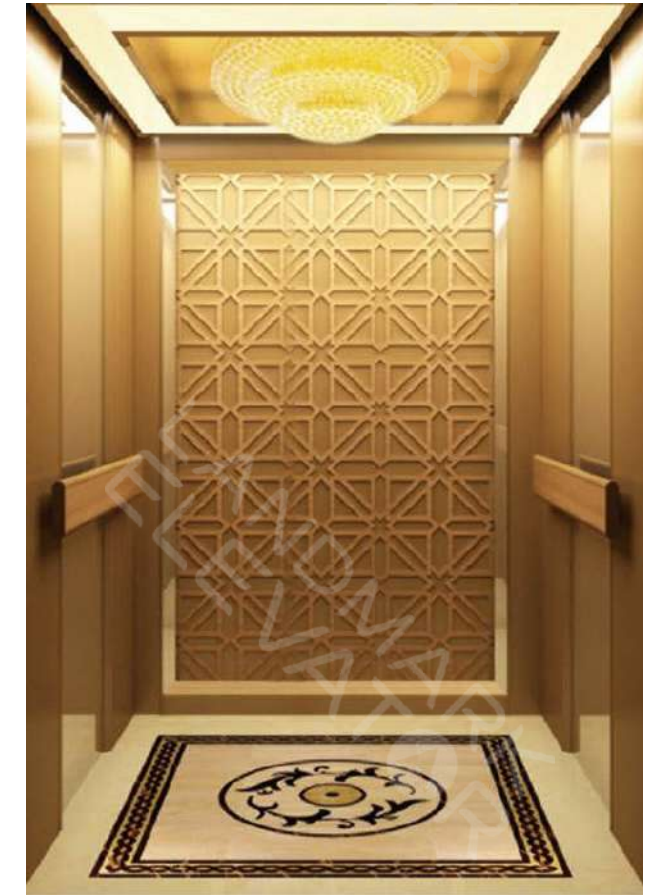

CBN-1302

Ceiling: Wood Frame + Golden Foil Veneer + LED Spotlight + LED Strip Lighting
 Rear Wall: Wood Veneer + Beveled Glass Mirror + Bronze Mirror ST. ST. Decorative Trim
 Side Wall: Wood Veneer + Beveled Glass Mirror + Bronze Mirror ST. ST. Decorative Trim
 Handrail: Golden ST. ST. Tube
 Skirting: Bronze Mirror ST. ST.
 Flooring: Marble
 Front Wall: Bronze Mirror ST. ST.

CBN-1303

Ceiling: Golden Brushed ST. ST. + LED Spotlight + Golden Foil veneer + LED Strip Lighting
 Rear Wall: Golden Brushed ST. ST. + Golden Mirror ST. ST. + Hollow Wood Carving
 Side Wall: Golden Brushed ST. ST. + Simulated Leather Veneer
 Handrail: Golden Brushed ST. ST. Tube
 Flooring: Marble
 Front Wall: Golden Brushed ST. ST.

CBN-1304

Ceiling: Rose-gold Mirror ST. ST. Frame + Enameled Steel + LED Spotlight + Ceiling-mounted Lantern
 Rear Wall: Rose-gold Mirror ST. ST. Etching + Rose-gold Mirror ST. ST.
 Side Wall: Rose-gold Brushed ST. ST. + Leather Veneer + Rose-gold Mirror ST. ST. Trim
 Handrail: Rose-gold ST. ST. Tube
 Flooring: Marble
 Front Wall: Rose-gold Mirror ST. ST.

CBN-1310

Ceiling: Champagne Quartz Mirror ST. ST. Frame + Cloudy Slice + Golden Foil Veneer + Decorative Lantern
 Rear Wall: Champagne Quartz Blasted ST. ST. + Champagne Quartz Mirror ST. ST. + Hollow Wood veneer + Glass
 Side Wall: Champagne Quartz Blasted ST. ST. + Champagne Quartz Mirror ST. ST.
 Handrail: Champagne Quartz Mirror ST. ST. + Wood Veneer
 Flooring: Marble
 Front Wall: Champagne Quartz Mirror ST. ST.

PASSENGER ELEVATOR



CBN-1337H

Ceiling: Rose-gold Mirror ST.ST.+ LED Spotlight
Rear Wall: Brushed ST.ST. Etching + Rose-gold Brushed ST. ST.
Side Wall: Brushed ST. ST. Etching + Rose-gold Brushed ST.ST.
Handrail: ST.ST.Tube
Flooring: Marble
Front Wall: Rose-gold Blasted ST. ST.



CBN-1338H

Ceiling: Wood Frame + Golden Mirror ST. ST.+LED Spotlight
+LED Strip Lighting
Rear Wall: Marble + Beveled Glass Mirror
Side Wall: Mirror ST.ST.+Wood Veneer
Handrail: Brushed ST.ST.+ Wood
Flooring: Marble
Front Wall: Mirror ST.ST.



CBN-1339H

Ceiling: Champagne Quartz Mirror ST. ST.+ LED Lighting
Rear Wall: Champagne Quartz Brushed ST. ST. + Champagne
Quartz Mirror ST. ST.
Side Wall: Wood Veneer
Handrail: Aluminum + ST. ST.
Skirting: Champagne Quartz Brushed ST. ST.
Flooring: Marble
Front Wall: Champagne Quartz Mirror ST. ST.



CBN-1340H

Ceiling: Brushed ST. ST. Frame + Acrylic
Rear Wall: Mirror ST. ST.+Laminated Steel
Side Wall: Blasted ST.ST.+ Laminated Steel + Mirror ST. ST.
Handrail: ST.ST.
Flooring: Marble
Front Wall: Mirror ST. ST.

PANORAMIC ELEVATOR

Car cover: Steel plate baking finish
 Observation wall: Laminated glass
 Decoration roof: LG-D17
 Car wall: Hairline stainless steel
 Handrail: Stainless steel pair tube
 Floor: PVC/Marble



Semicircle Type Panoramic Elevator



PAN-01
(Standard)



Central image arch, stainless steel baseplate is supplemented with soft lighting design of down lamp at both sides.



Pair stainless steel tube for handrail



PVC/Marble

Car cover: Painted steel plate, acrylic lighting decoration
 Observation wall: Square, glueglass of safety clamp
 Decoration roof: LG-D14
 Car wall: Hairline stainless steel
 Handrail: Stainless steel tube
 Floor: PVC/Marble



Square Type Panoramic Elevator



PAN-02
(Standard)



Stainless steel mirror base plate is supplemented with golden down lamp and car wall. Central part consists of soft lighting design of arched white light-emitting panel.



Matte short-grain stainless steel pipe



PVC/Marble

PANORAMIC ELEVATOR



PAN-1402

Canopy: Enameled Steel + LED Spotlight +Acrylic
 Ceiling: Mirror ST. ST.+ LED Spotlight +LED Strip Lighting
 Scenic Wall:Laminated Safety Glass
 Walls:Mirror ST.ST. Etching
 Handrail:ST.ST.Tube
 Inner Sill:Mirror ST.ST.
 Flooring:Marble
 Front Wall:Brushed ST.ST.
 Car Door:Brushed ST. ST.+Framed Glass Door



PAN-1403

Canopy: Enameled Steel + Mirror ST. ST.+Acrylic
 Ceiling: Enameled Steel + Mirror ST.ST.+ LED Spotlight
 Scenic Wall:Laminated Safety Glass
 Walls:Brushed ST.ST.
 Handrail:ST.ST.Tube
 Inner Sill:Brushed ST.isT.
 Flooring:Marble
 Front Wall:Brushed sT.sT.
 Car Door:Brushed ST ST.



PAN-1404

Canopy:Golden Mirror ST.ST.+ LED Spotlight
 Ceiling: Enameled Steel + Laminated Glass +LED Spotlight
 Scenic Wall:Laminated Safety Glass
 Walls:Golden Mirror ST.ST.Etching + Golden Mirror ST.ST.
 Handrail:Golden ST.ST.Tube
 Inner Sill:Golden Mirror ST.ST.
 Flooring:Marble
 Front Wall:Golden Mirror ST.ST.
 Car Door: Golden Mirror ST.ST.Etching



PAN-1405

Canopy: Enameled Steel + Acrylic
 Ceiling: Eriameled Steel + Acrylic + LED Spotlight
 Scenic Wali:Laminated Safety Glass
 Walls: Golden Mirror ST. ST. Etching
 Handrail: Golden ST. ST.Tube
 Inner Sill: Golden Mirror ST.ST.
 Flooring: Marble
 Front Wall: Golden Mirror ST. ST.
 Car Door: Golden Mirror ST. ST.

PANORAMIC ELEVATOR



PAN-1417

Outer Decoration: Brushed ST.ST.
 Ceiling: Mirror ST.ST. + LED Spotlight
 Scenic Wall: Laminated Safety Glass
 Walls: Mirror ST.ST.
 Handrail: ST.ST. Tube
 Inner Sill: Mirror ST.ST.
 Flooring: Marble
 Front Wall: Laminated Safety Glass
 Car Door: Mirror ST.ST. Framed Glass Door



PAN-1418

Outer Decoration: Brushed ST. ST.
 Ceiling: Brushed ST.ST. + Acrylic
 Scenic Wall: Laminated Safety Glass
 Walls: Brushed ST.ST. + Back-painted Glass
 Handrail: ST.ST. Tube
 Flooring: Marble
 Front Wall: Brushed ST.ST. + Back-painted Glass
 Car Door: Brushed ST.ST. Framed Glass Door

A



PAN-1419

Outer Decoration: Brushed ST.ST.
 Ceiling: Mirror ST.ST. + LED Spotlight
 Scenic Wall: Laminated Safety Glass
 Walls: Mirror ST.ST.
 Handrail: ST.ST.
 Tube Inner Sill: Mirror ST.ST.
 Flooring: Laminated Safety Glass Frosted + Marble
 Front Wall: Laminated Safety Glass
 Car Door: Mirror ST.ST. Framed Glass Door

B

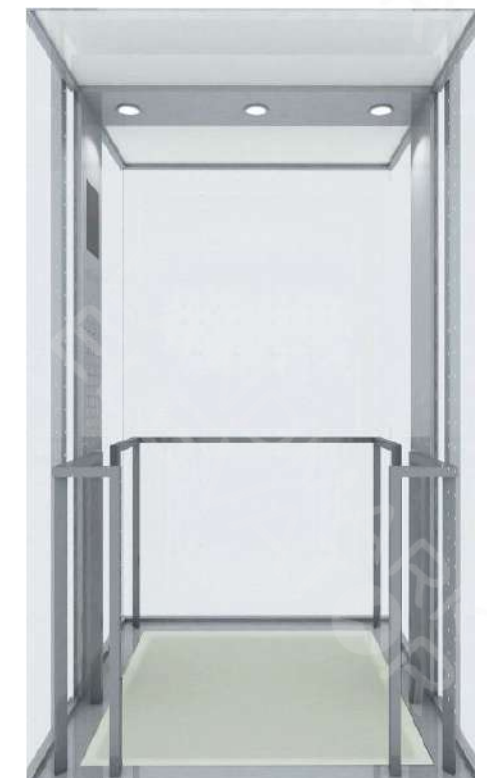

HOME ELEVATOR

Home elevator is not only an elevator in your building, but also a taste of quality, which upgrades your home comfort and living quality. Our home elevator follows the design concept of "Quality, Taste, Customization, Profession", and applies advanced intelligent technology, to lift up your life of quality.



Shaft Frame



Circle internal and external glass structure

Semicircle external glass structure

Square external glass structure

Shaft glass color optional selection



Frosted glass



Transparent glass



Brown glass



Dark grey glass

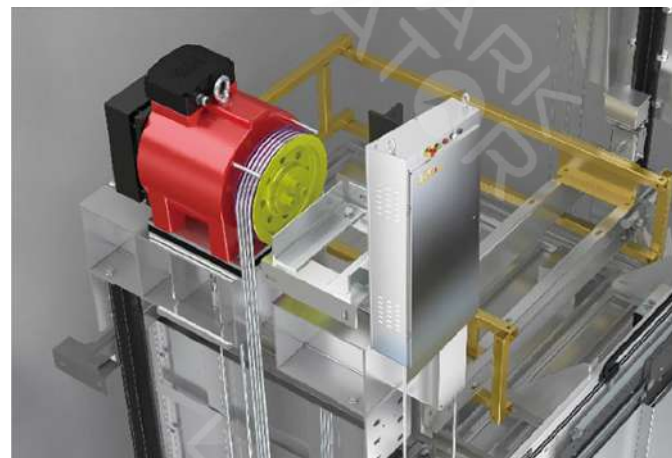

Traction-type Home Elevator

It is no need of a dedicated machine room. It only takes a small area in shaft. It has low requirement from the overhead height and pit depth. It is suitable for various villa structures. It can run stably, without unbalanced load.



Steel Belt-type Home Elevator

It changes the traditional motor technology, and adopts the design with integrated drive and traction system. It is much more efficient in energy saving and environment protection. The flat steel belt is an advanced option.

Different Doors Of Home Elevator



Mirror stainless steel



Short hairline stainless steel (Anti-fingerprint)



Automatic glass door



Rose gold stainless steel



Rose gold mirror etching stainless steel



Titanium mirror etching stainless steel



Glass door with gold frame by hand



Glass door with by hand

FREIGHT ELEVATOR

Freight elevator is widely used in the workshop, office buildings to carry large heavy goods. Its loading capacity ranges from 1000kg to 10000kg.



Your Goods Transportation Expert

- The latest traction technology and the advanced driving and feedback technology are used to make the freight elevator run perfectly with comfort.
- Realize the precise and stable levelling with lower noise , and sturdy and durable use.
- Large door opening space, adopt multi-folding lift car door , to realize maximum width for door opening. It is convenient for large goods to enter and exit.



Side opening (This is for reference only.)

Side Opening

FRT-01 (Standard)

Car top: Painted steel
Ventilation: Circular fan
Car wall: Painted steel
Car door: Painted steel
Car floor: Chequered plate steel
Sill: Iron

2-Panels Center Opening

FRT-02 (Standard)

Car top: Painted steel
Ventilation: Circular fan
Car wall: Painted steel
Car door: Painted steel
Car floor: Chequered plate steel
Sill: Iron

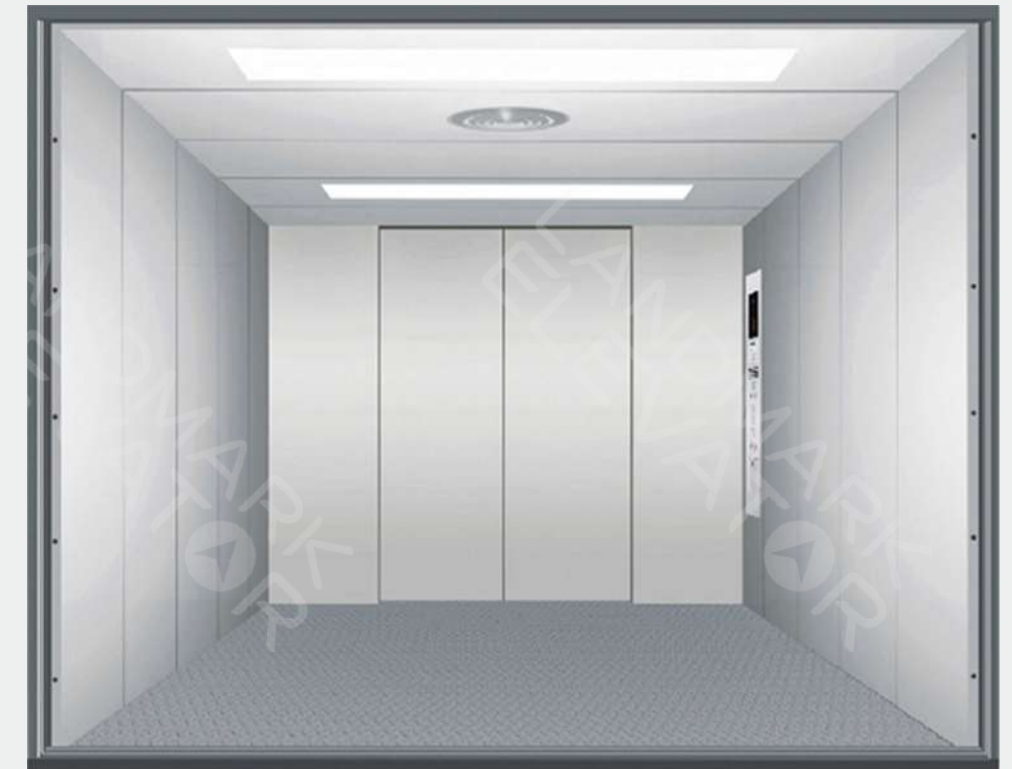

ESCALATOR EIGHT SAFETY DESIGNS

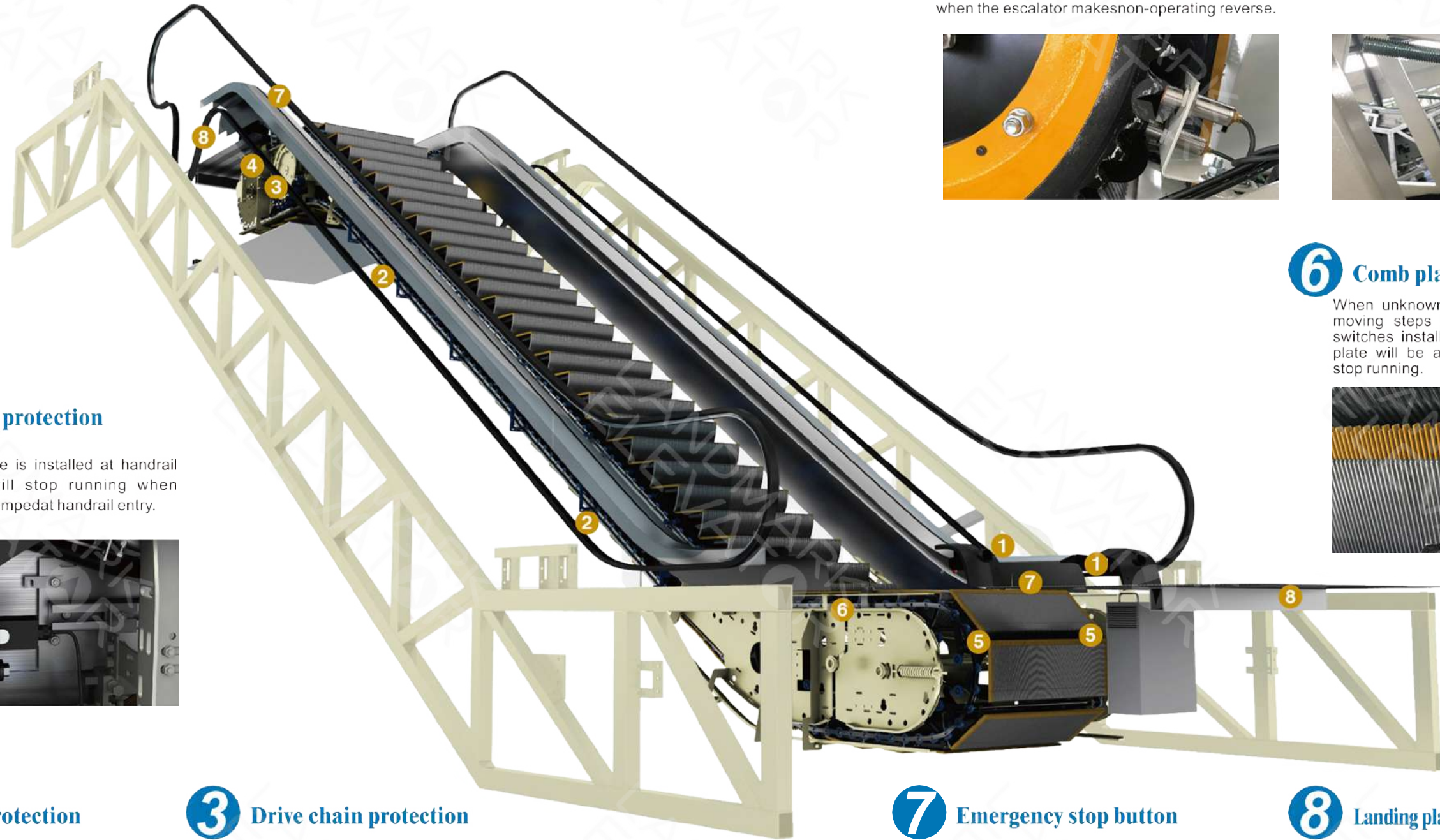

1 Handrail entry protection

Safety protective device is installed at handrail entry. The escalator will stop running when unknown objects are clamped at handrail entry.



2 Step sagging protection

In order to guarantee the passengers' and equipment's safety, the escalator will stop running when the step is sagging or broken.



3 Drive chain protection

The escalator will stop running when the drive chains are overpulled or broken.



4 Anti-reversal protection

Speed and running direction sensors are installed at machineside. The machine will safety brake when the escalator makes non-operating reverse.



5 Step chain break protection

The escalator will stop running when the step chain is broken, overpulled or overshortened.



6 Comb plate protection

When unknown objects are placed in between moving steps and static comb plate, the safety switches installed to monitor two sides of comb plate will be activated, thus the escalator will stop running.



7 Emergency stop button

The escalator will stop running when the button is pressed.



8 Landing plate opening protection device

The landing plate safety switch will be activated when landing plate is opened, which will cut off the safety circuit and the escalator stops running.



ELEVATOR PROFILEVIEWS

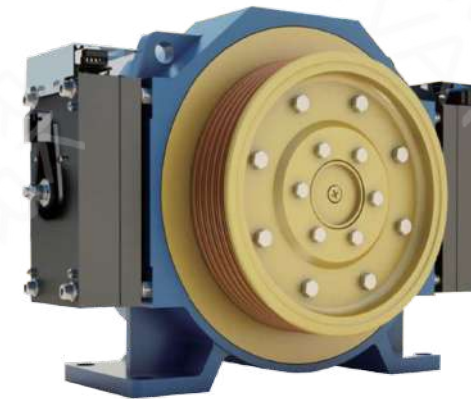
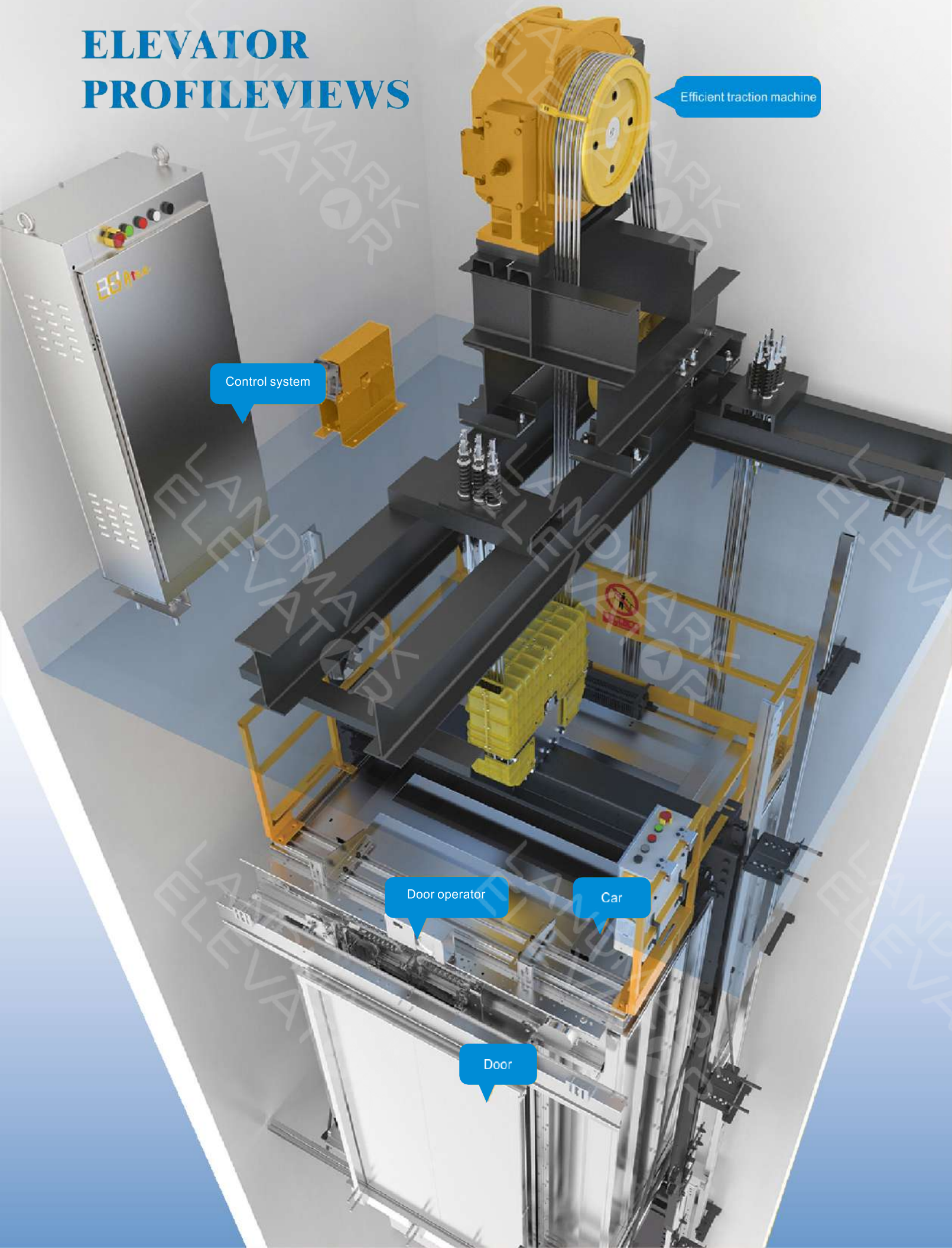

Permanent Magnet Synchronous Gearless Traction Machine

Landmark Elevator adopts the permanent magnet synchronous gearless machine with the latest technology. This machine is widely used now in all kinds of buildings, like offices, residential buildings, shopping mall,s hospitals, airports etc. It is suitable for machine room to machine room less.



New Control Technology

Landmark always develops the new series of control systems, to meet the high quality needs of the clients, and to win the market share. This integrated drive system makes the elevator perform quite easy with comfort and safety.

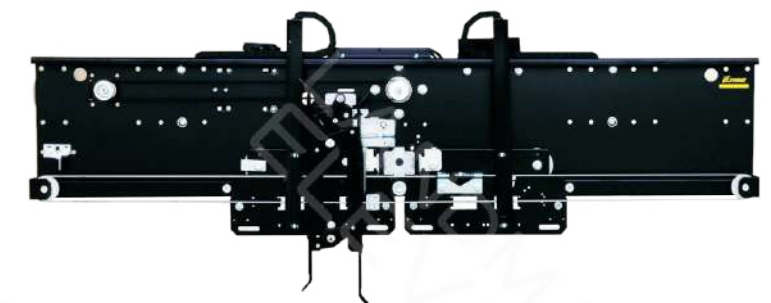

VVVF Door Operator

Landmark Elevator uses the new generation of VVVF synchronous door systems to make the door open and close more smoothly. The car door is equipped with infrared light curtain system for the door safety protection, to ensure the safety of the passengers.

CAR CEILING



CLG-1401
Brushed ST. ST. Frame +Acrylic



CLG-1402
Golden Mirror ST.ST. Frame +Acrylic +LED Spotlight

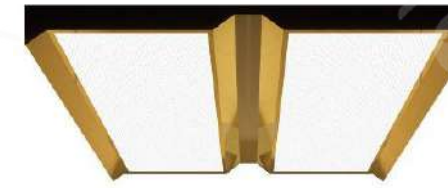

CLG-1409
Golden Mirror ST. ST. Frame + Colored Acrylic



CLG-1410
Painted Steel +LED Spotlight+ LED Strip Lighting



CLG-1403
Mirror ST. ST. Frame + Colored Acrylic + LED Spotlight



CLG-1404
Mirror ST. ST. Frame + Acrylic

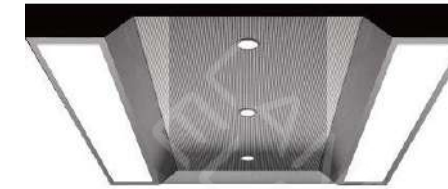

CLG-1411
Mirror ST.ST. Frame + Mirror ST.ST Etching + Acrylic+ LED Spotlight

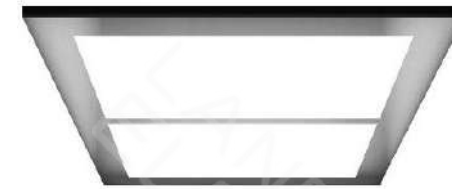

CLG-1412
Mirror ST.ST.+Acrylic



CLG-1405
Rose-gold Mirror ST.ST. Frame + Acrylic



CLG-1406
Painted Steel Frame + Mirror ST. ST.+ Acrylic



CLG-1413
Brushed ST.ST.+Acrylic

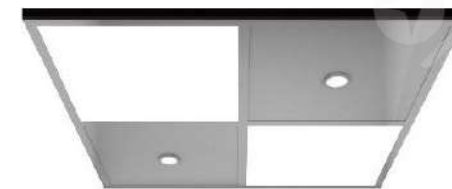

CLG-1414
Mirror ST.ST.+Acrylic+ LED Spotlight



CLG-1407
Brushed ST. ST. Frame +Acrylic+ LED Spotlight



CLG-1408
Mirror ST. ST. Frame +Acrylic



CLG-1415
Mirror ST.ST.+ LED Spotlight



CLG-1416
Mirror ST.ST.+ Acrylic

CAR FLOOR AND HANDRAIL



FLR-1401



FLR-1402



FLR-1403



FLR-1404



FLR-1405



FLR-1406



FLR-1407



FLR-1408

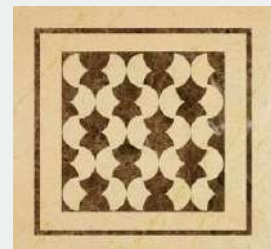

FLR-1409



FLR-1410



FLR-1411

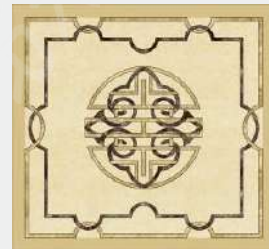

FLR-1412

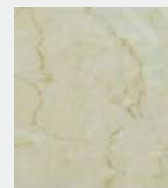

7705



7703



TM-746A

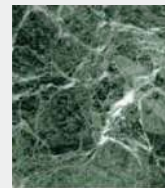

7702



7707

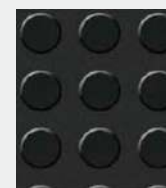

anti-slippery



HDR-1401



HDR-1402



HDR-1403



HDR-1404



HDR-1405



HDR-1406



HDR-1407



HDR-J015



HDR-6F1



HDR-9707



HDR-9701



HDR-J013

OPERATION PANEL

Split type operation panelseries

Smart maneuvering experience ,

Have comprehensive understanding about slight change in elevator products

Rapid response, timely feedback Products are close to people.



Split type operation panelseries

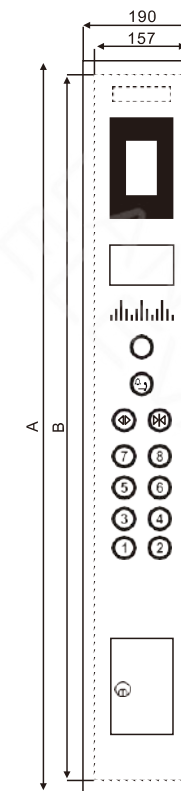

COP-01

No	A	B	Suitable Floor
01	1210	1170	02-12F
02	1390	1350	13-20F
03	1570	1530	21-28F

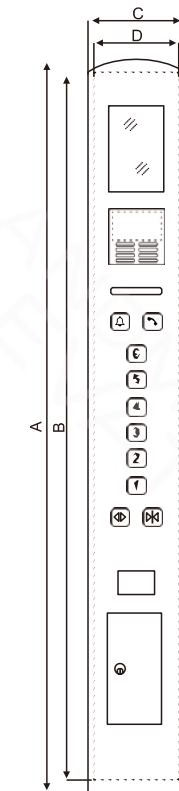

COP-02

No	A	B	C	D	Suitable Floor
01	1380	1330	180	160	02-14F
02	1580	1530	180	160	15-26F
03	1580	1530	210	190	27-36F

OPERATION PANEL

Integrated operating panelseries

Seamless connection display beauty of modern technology

It perfectly combines with the elevator car, attractive and graceful, convenient installation

Visual electronic displayer, flexible response, appropriate brightness Smart elevator indicate perfectness



Integrated operating panelseries

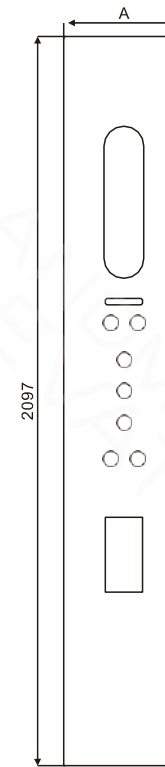

CY-01

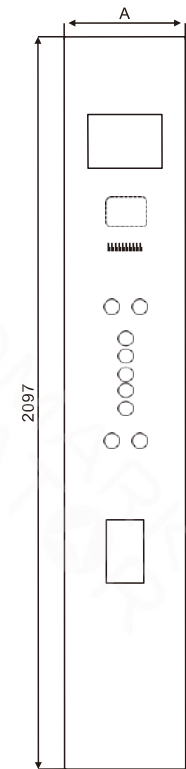

CY-02

Front side-open panel
Side wall hing

- Stainless steel face plate, selection for hairline, mirror, titanic golden
- Integrated design(no need front-enclosed wall), openable design, convenient for maintainance
- Multiple display mode(Dot matrix, Liquid crystal, Photo machine, video machine)

OPERATION PANEL

Split type operation panel series

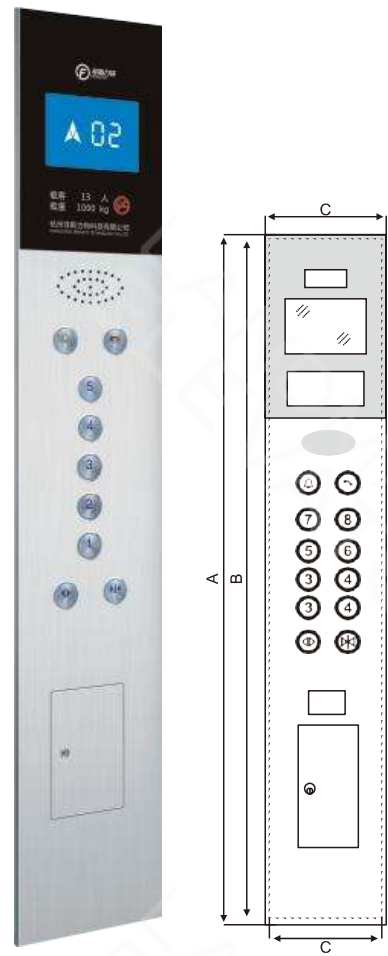

COP-03

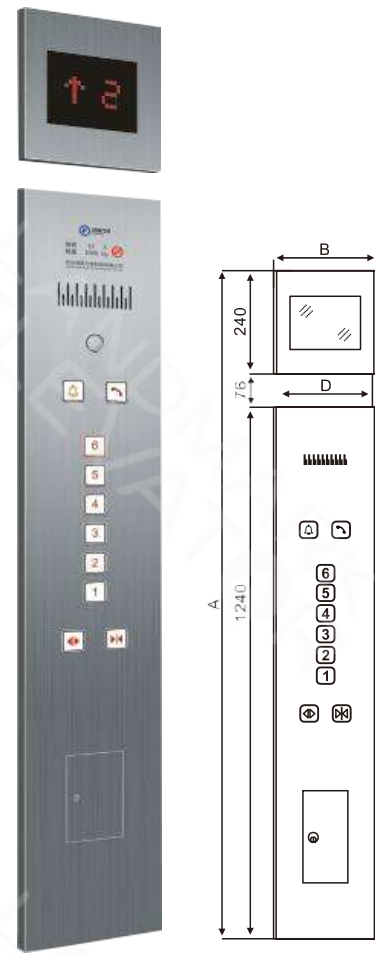

COP-04

No	A	B	C	D	Suitable Floor
01	1180	1160	167	155	02-12F
02	1180	1160	207	195	02-12F
03	1360	1340	167	155	13-20F
04	1360	1340	207	195	13-20F

No	A	B	C	D	Suitable Floor
01	1556	240	1540	220	02-20F

Split type operation panel series

- Unique sense of color
- Cold brushed metal
- Intersperse with warm
- Emotion of industrial aesthetics is warming
- Perfect integration between the two



OPERATION PANEL

Disabled person operation panel series

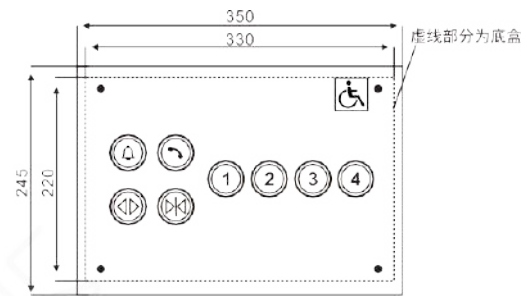

Villa elevator operation panel series

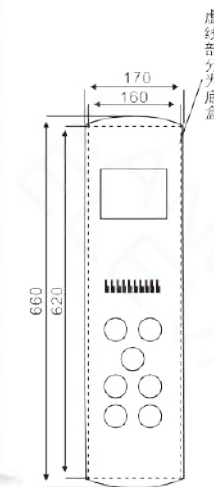

CV-01

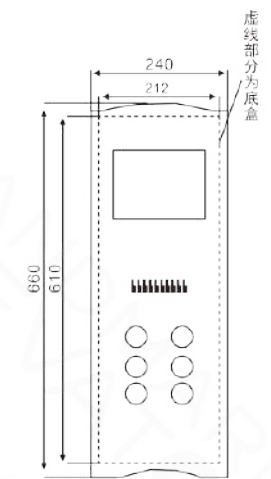

CV-02

CONSTRUCTION LAYOUT DRAWING

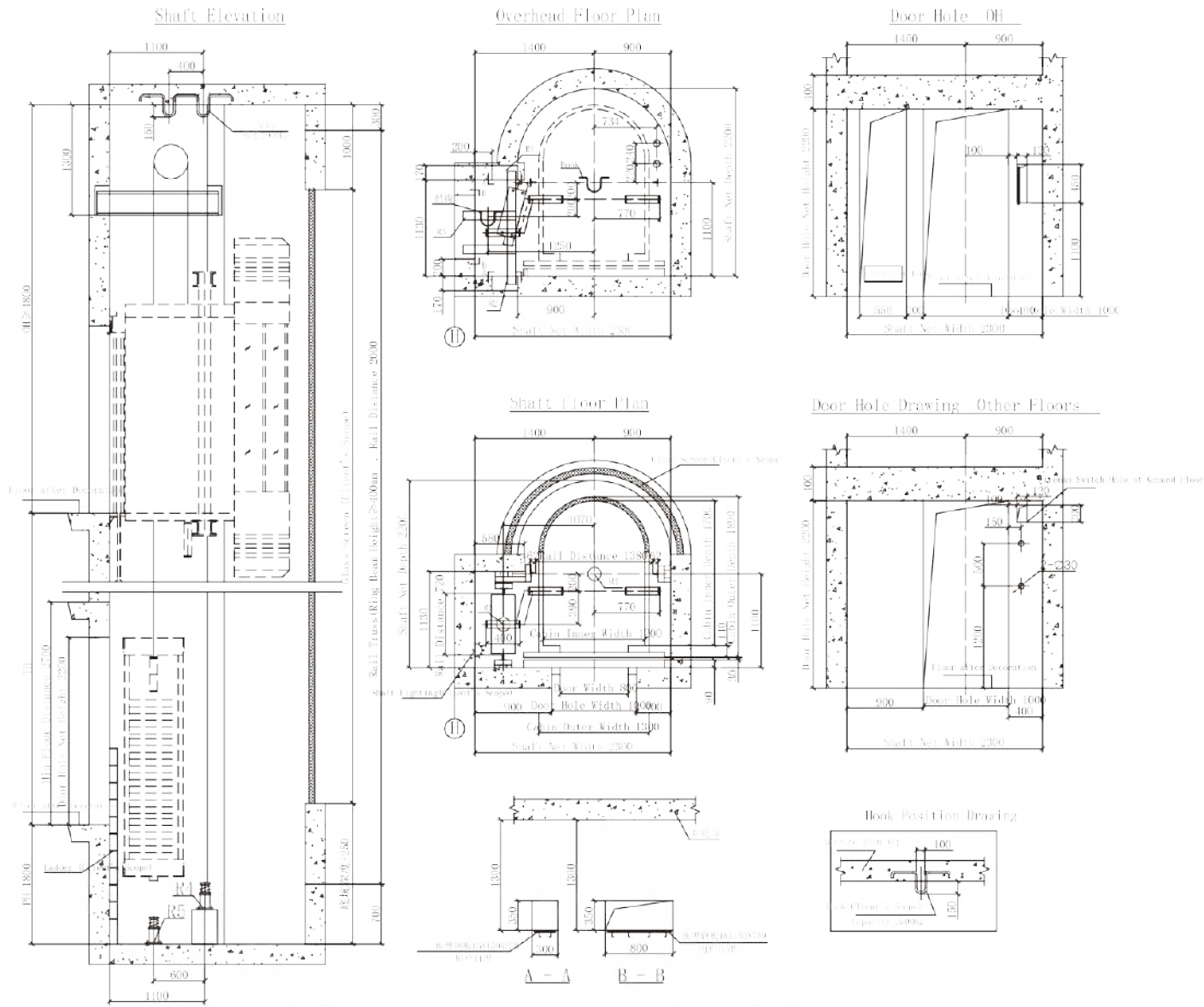

Panoramic Elevator MR

CONSTRUCTION LAYOUT DRAWING

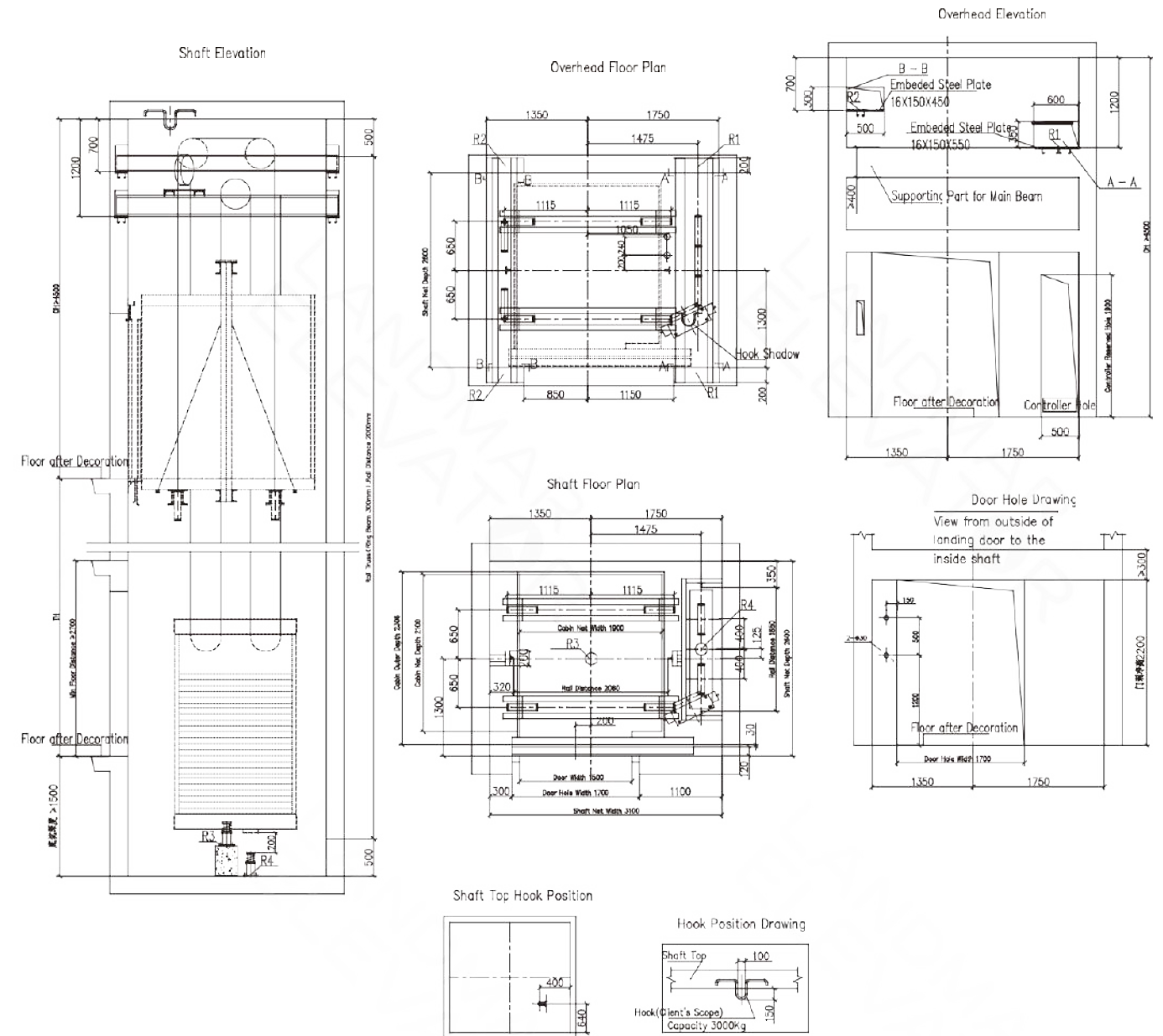

Freight Elevator MRL

CONSTRUCTION LAYOUT DRAWING

CONSTRUCTION LAYOUT DRAWING

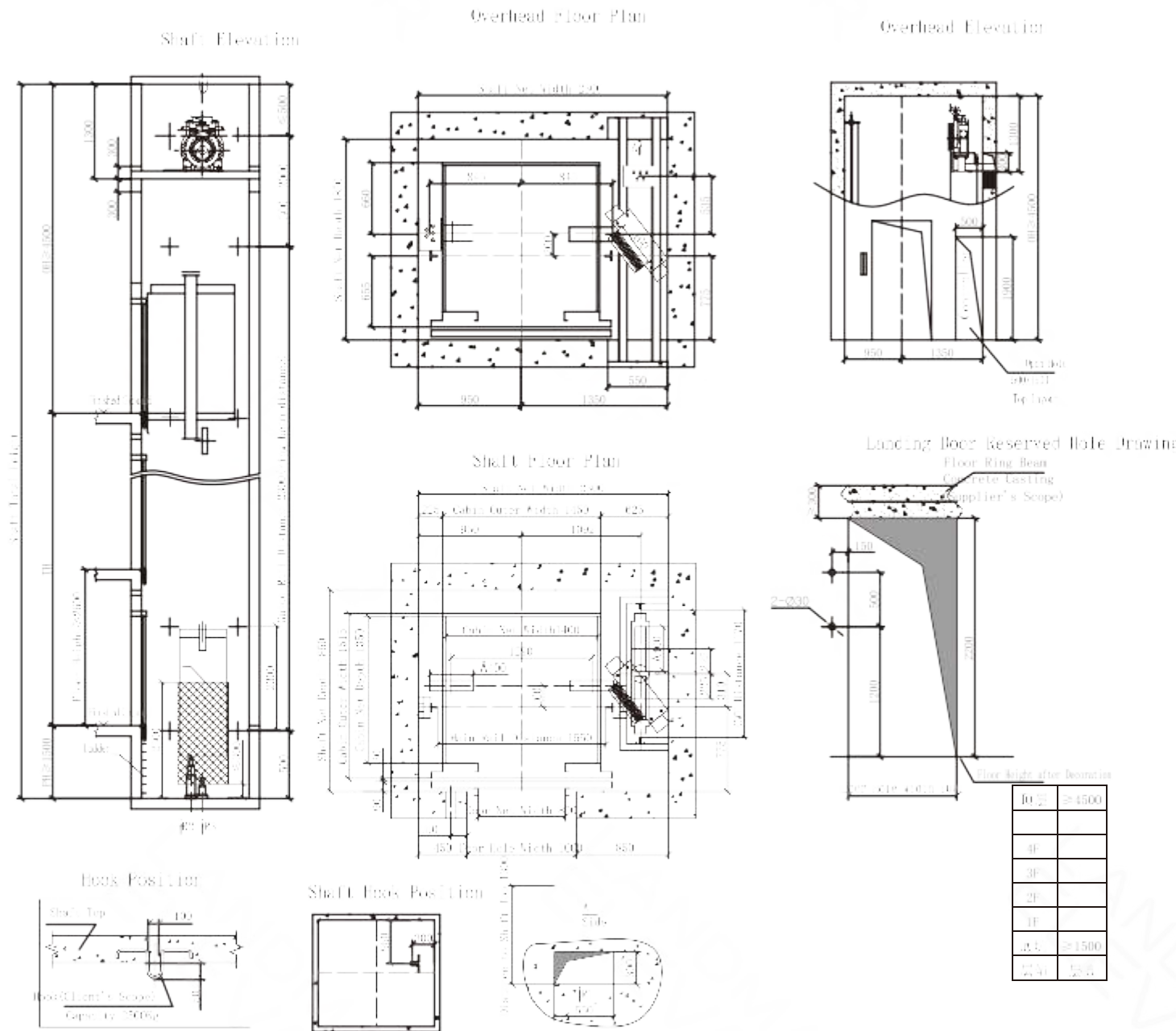

Passenger Elevator MRL

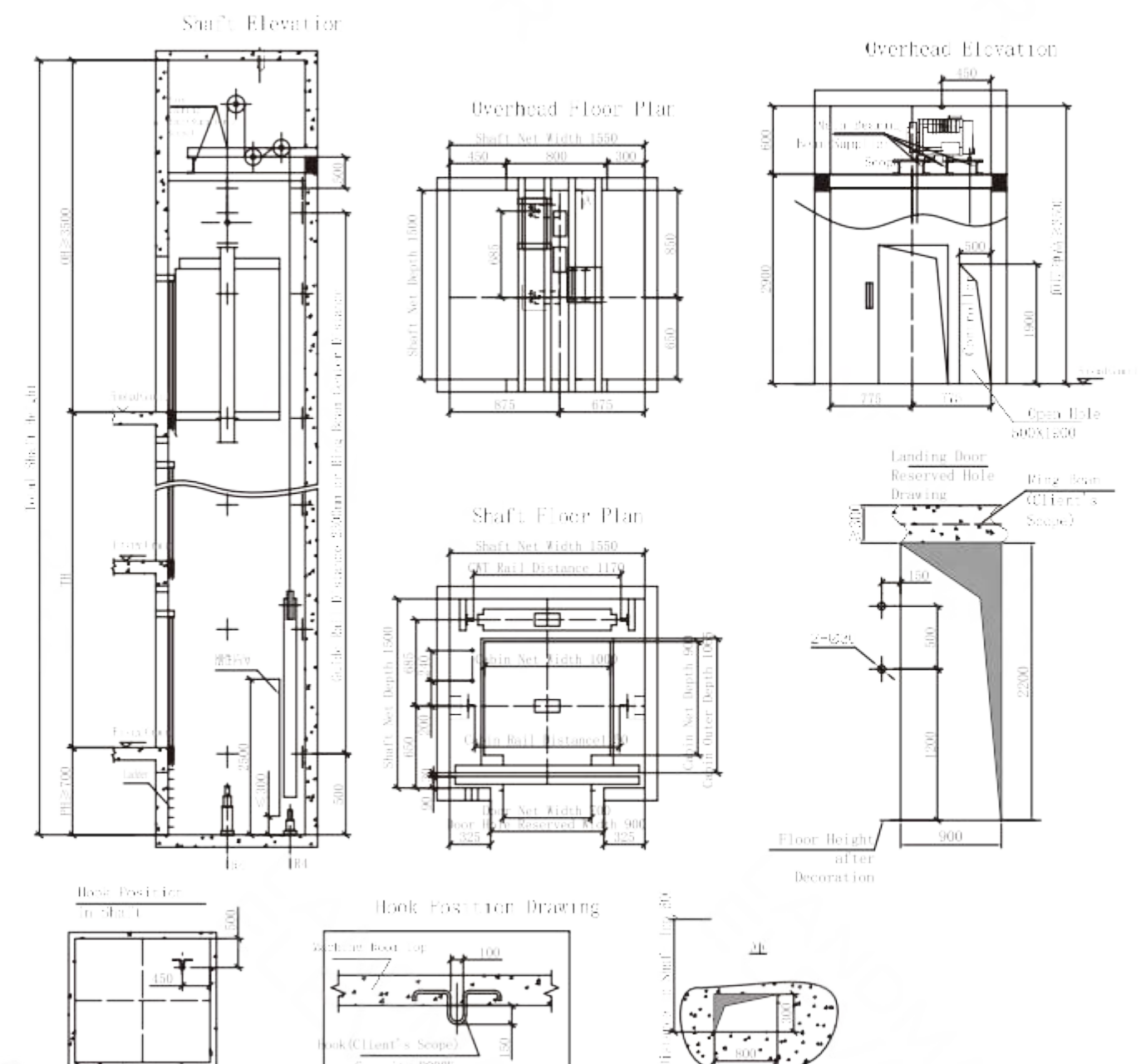

Home Elevator MR

CONSTRUCTION LAYOUT DRAWING

CONSTRUCTION LAYOUT DRAWING

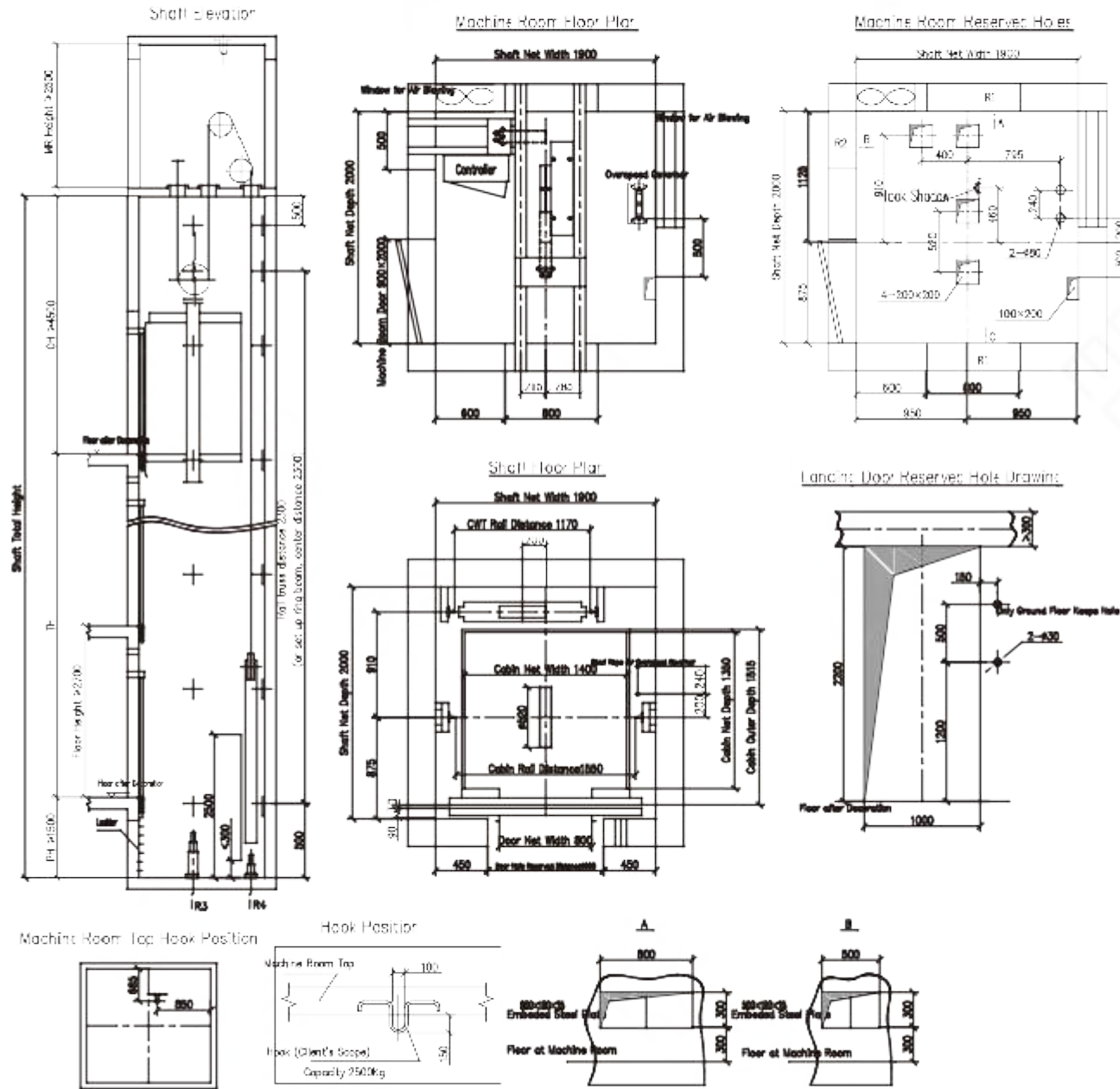

Passenger Elevator MR

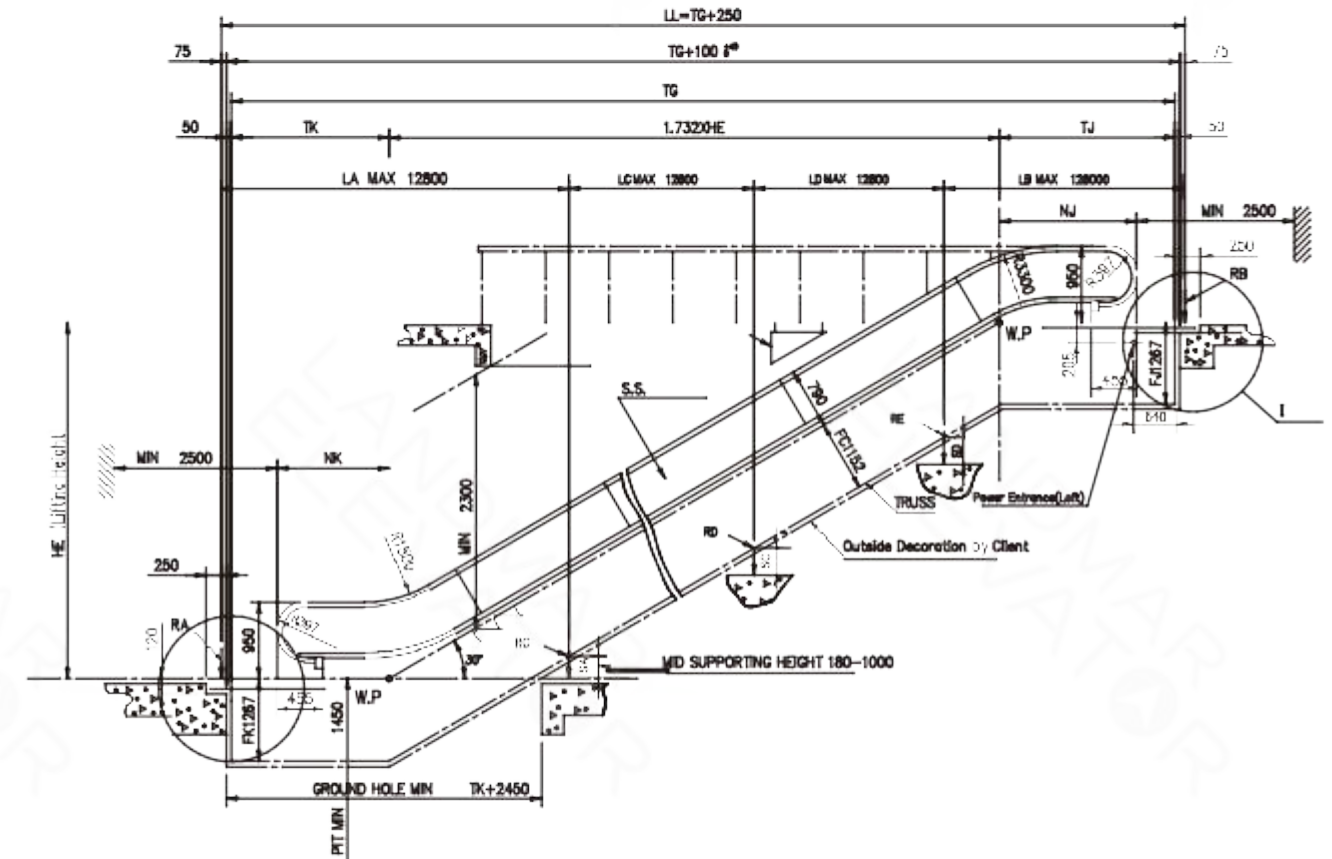

Note: This drawing is only suitable for indoors. If it is for outdoors, sizes will be modified accordingly.

Speed(m/s)	0.5m/s		0.65m/s		
	Lifting Height(m)	Motor Power*Qty	Power Capacity	Motor Power*Qty	Power Capacity
3000-4080	7.5(KW)*1	11(KVA)	9(KW)*1	12(KVA)	
4080-6160	7.5(KW)*2	20(KVA)	9(KW)*2	20(KVA)	
6160-12240	7.5(KW)*4	30(KVA)	9(KW)*4	34(KVA)	
12240-16320	7.5(KW)*6	35(KVA)	9(KW)*6	38(KVA)	
16320-20000	7.5(KW)*8	37(KVA)	9(KW)*8	41(KVA)	

Specifications	
Type	INDOOR
Step Width	1004 mm
W(Escalator Width)	1550 mm
R2(Handrail Width)	1280 mm
R3(Start Panel Width)	1000 mm
Lifting Height	3m<E>20m
Convey Capacity	9000 people/hour 11700 people/hour
Speed	0.5m/s 0.65m/s
Power	30KW-50KW-50Phase
Drive System	Direct Drive
Used Places	Indoors

Escalator INDOORS